

US009160222B1

(12) **United States Patent**  
**Kim et al.**

(10) **Patent No.:** **US 9,160,222 B1**  
(45) **Date of Patent:** **Oct. 13, 2015**

(54) **APPARATUS WITH POWER GENERATORS  
DRIVEN BY ELECTRIC MOTORS**

(71) Applicant: **K-TECHNOLOGY USA, INC.**, Los Angeles, CA (US)

(72) Inventors: **Ki Il Kim**, Los Angeles, CA (US);  
**Young Kim**, Los Angeles, CA (US);  
**Sarah Duncanson**, Toluca Lake, CA (US);  
**Sandra Dyche**, Vernon, CA (US)

(73) Assignee: **K-TECHNOLOGY USA, INC.**, Los Angeles, CA (US)

(\*) Notice: Subject to any disclaimer, the term of this patent is extended or adjusted under 35 U.S.C. 154(b) by 0 days.

2,032,112 A	2/1936	Brecht
2,053,419 A	9/1936	Brecht
2,053,983 A	9/1936	Whitsitt
2,624,870 A	1/1953	Kolanda et al.
3,556,239 A	1/1971	Spahn
3,559,724 A	2/1971	Wilkinson
3,575,562 A	4/1971	Remke
3,584,214 A	6/1971	Peterson
3,608,925 A	9/1971	Murphy
3,867,058 A	2/1975	Hendrickson
4,021,677 A	5/1977	Rosen et al.
4,150,914 A	4/1979	Karlsson
4,246,988 A	1/1981	Hoppie
4,314,160 A	2/1982	Boodman et al.
4,351,405 A	9/1982	Fields et al.
4,405,028 A	9/1983	Price
4,414,462 A	11/1983	Price

(Continued)

(21) Appl. No.: **14/473,390**

(22) Filed: **Aug. 29, 2014**

(51) **Int. Cl.**

<b>H02K 47/00</b>	(2006.01)
<b>H02K 7/10</b>	(2006.01)
<b>H02K 51/00</b>	(2006.01)
<b>H02K 7/20</b>	(2006.01)
<b>H02K 7/18</b>	(2006.01)
<b>H02K 53/00</b>	(2006.01)

(52) **U.S. Cl.**

CPC ..... **H02K 47/00** (2013.01); **H02K 53/00** (2013.01); **Y10S 74/09** (2013.01)

(58) **Field of Classification Search**

CPC ..... B64D 29/00; H02K 53/00  
USPC ..... 310/75 R, 83, 98, 99, 101, 102 R, 112, 310/113, 118, 122; 290/1 A, 1 D, 4 A, 4 C  
See application file for complete search history.

(56) **References Cited**

**U.S. PATENT DOCUMENTS**

1,537,071 A	5/1925	Farley
1,985,679 A	12/1934	Jenkins
2,026,076 A	12/1935	Spicer

**FOREIGN PATENT DOCUMENTS**

FR 2657474 A1 \* 7/1991

**OTHER PUBLICATIONS**

Aircraft Ram Air Turbine, Aug. 17, 2012, available online at <http://turbinatop.net/aircraft-ram-air-turbine/>.

*Primary Examiner* — Dang Le

*Assistant Examiner* — Jose Gonzalez Quinones

(74) *Attorney, Agent, or Firm* — Novick, Kim & Lee, PLLC; Jae Youn Kim

(57) **ABSTRACT**

Provided is an apparatus including electric power generators. The apparatus includes an electric motor that drives a power generator for generating power that is supplied to rotate another electric motor for driving a plurality of power generators.

**10 Claims, 1 Drawing Sheet**

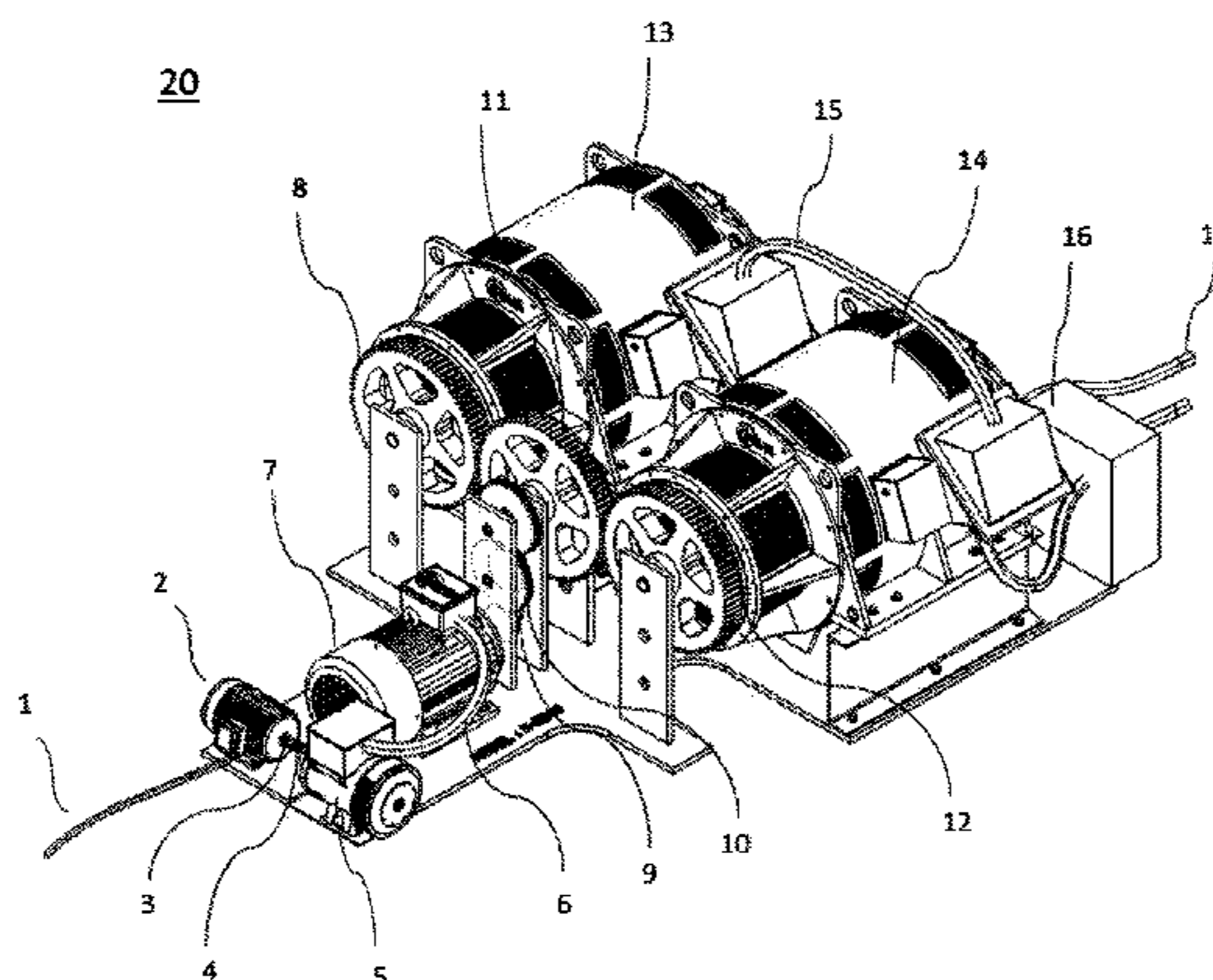

(56)

References Cited

U.S. PATENT DOCUMENTS

4,433,294	A	2/1984	Windebank	2008/0263731	A1	10/2008	Tabe
4,457,237	A	7/1984	Theurer et al.	2009/0181609	A1	7/2009	Thomas
4,684,817	A	8/1987	Goldwater	2009/0267348	A1	10/2009	Liebermann
4,748,338	A	5/1988	Boyce	2009/0301796	A1	12/2009	Wedderburn et al.
5,179,335	A	1/1993	Nor	2010/0087976	A1	4/2010	Aridome et al.
5,225,763	A	7/1993	Krohn et al.	2010/0107994	A1	5/2010	Moriarty et al.
5,296,746	A	3/1994	Burkhardt	2010/0140006	A1	6/2010	Frierman
5,362,280	A	11/1994	Hirai et al.	2010/0167602	A1	7/2010	Vu
5,566,795	A	10/1996	Barefoot	2010/0237627	A1	9/2010	Socolove et al.
5,680,032	A	10/1997	Pena	2010/0270810	A1	10/2010	Liebermann
5,920,127	A	7/1999	Damron et al.	2010/0315040	A1	12/2010	Sakurai
5,921,334	A	7/1999	Al-Dokhi	2011/0101698	A1	5/2011	Saluccio
5,927,094	A	7/1999	Nickum	2011/0156404	A1	6/2011	Haddad
6,076,516	A	6/2000	Tucker	2011/0162924	A1	7/2011	Laxhuber
6,474,242	B1	11/2002	Baier	2011/0198856	A1	8/2011	Ling
6,897,575	B1	5/2005	Yu	2011/0248666	A1	10/2011	Loreson
7,478,693	B1	1/2009	Curtis	2011/0260470	A1	10/2011	Ahmadi
7,653,464	B1	1/2010	Mitra	2011/0266075	A1	11/2011	Guzelimian
7,763,988	B1	7/2010	Dravis	2011/0309786	A1	12/2011	Hassan
8,098,040	B1	1/2012	Botto	2012/0085587	A1	4/2012	Drouin
8,371,401	B1	2/2013	Illustrato	2012/0125700	A1	5/2012	Bailey
8,436,485	B1	5/2013	Smith	2012/0132411	A1	5/2012	Park et al.
8,509,992	B1	8/2013	Bosworth	2012/0133314	A1	5/2012	Kozarekar et al.
8,513,828	B1	8/2013	Ripley	2012/0169061	A1	7/2012	Lee et al.
8,701,804	B1	4/2014	Antrobus	2012/0249065	A1	10/2012	Bissonette et al.
2002/0066608	A1	6/2002	Guenard et al.	2012/0286513	A1	11/2012	Marano
2002/0153178	A1	10/2002	Limonius	2012/0298790	A1	11/2012	Bitar
2002/0187033	A1	12/2002	Stahler	2012/0299526	A1	11/2012	Lambert
2003/0209370	A1	11/2003	Maberry	2012/0299527	A1	11/2012	Vo
2004/0080227	A1*	4/2004	Tung Kong et al. .... 310/112	2012/0330488	A1	12/2012	Sadler
2005/0046195	A1	3/2005	Kousoulis	2013/0009469	A1	1/2013	Gillett
2005/0210858	A1	9/2005	Gore et al.	2013/0026989	A1	1/2013	Gibbs et al.
2006/0047398	A1	3/2006	Abe et al.	2013/0043082	A1	2/2013	Tran
2006/0213697	A1	9/2006	Sutherland	2013/0063071	A1	3/2013	Walters
2006/0273596	A1	12/2006	Durbin	2013/0127393	A1	5/2013	Garcia
2007/0077967	A1	4/2007	Nicholls et al.	2013/0168962	A1	7/2013	Bruno
2007/0126238	A1	6/2007	Augusto	2013/0175954	A1	7/2013	Astigarraga et al.
2007/0296222	A1*	12/2007	Blackman ..... 290/1 A	2013/0175974	A1	7/2013	Bassham et al.
2008/0041643	A1	2/2008	Khalife	2013/0184916	A1	7/2013	Goodwin
2008/0202825	A1	8/2008	Kerish	2013/0289809	A1	10/2013	Treharne et al.
2008/0231052	A1	9/2008	Farmer	2013/0306389	A1	11/2013	Penev
2008/0257614	A1	10/2008	Tabe	2013/0314023	A1	11/2013	Collier
				2013/0328318	A1	12/2013	Ozawa
				2014/0076641	A1	3/2014	Penev

\* cited by examiner

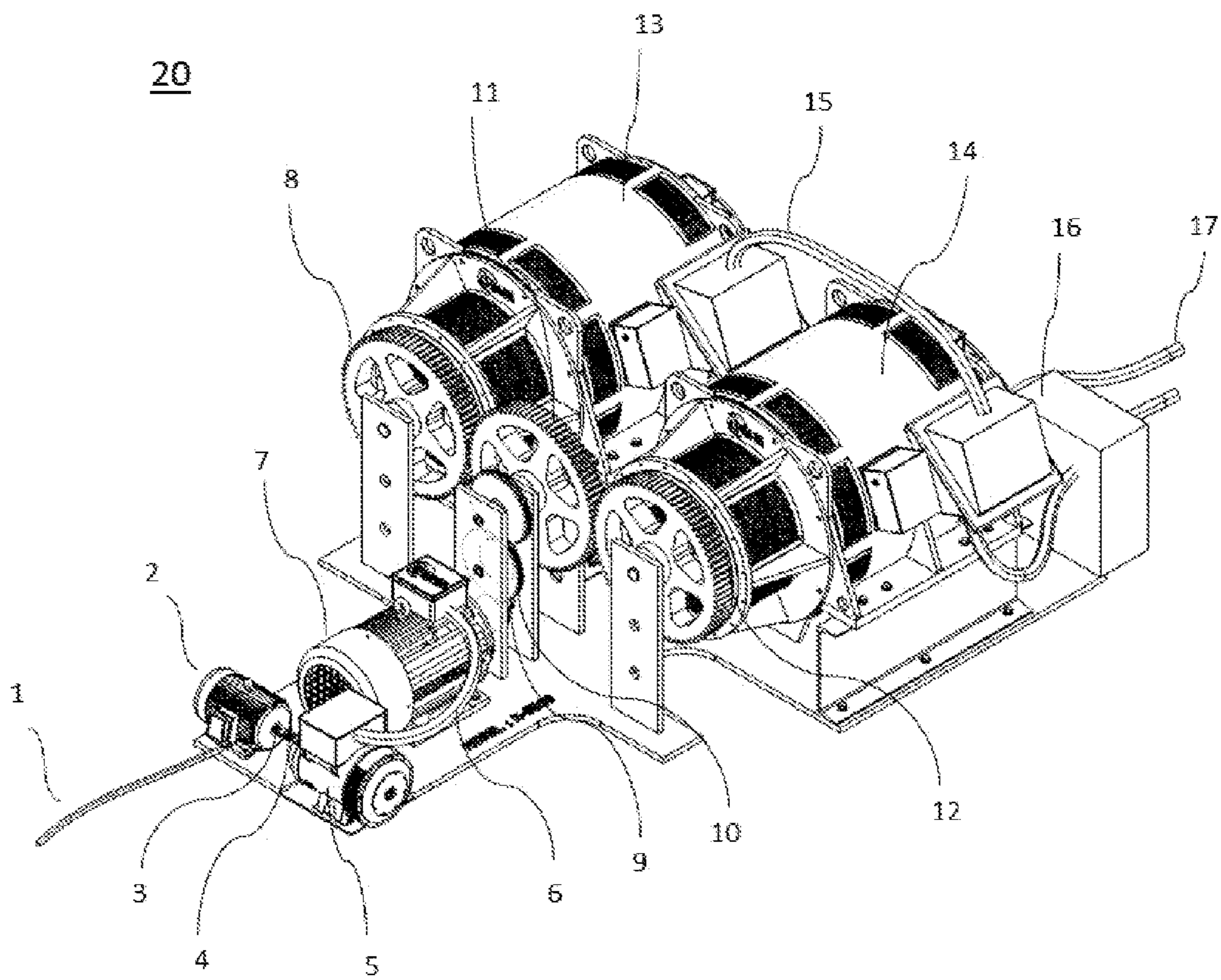

## APPARATUS WITH POWER GENERATORS DRIVEN BY ELECTRIC MOTORS

### BACKGROUND OF THE INVENTION

One or more embodiments of the present invention relate to an apparatus provided with electric power generators. The apparatus includes an electric motor that drives a power generator for generating power that is supplied to rotate another electric motor for driving a plurality of power generators.

### SUMMARY OF THE INVENTION

An aspect of the present invention provides an apparatus that includes a first electric motor; a first power generator connected to and driven by the first electric motor to generate power; a second electric motor driven by the power generated by the first power generator; a first gear engaged with and driven by the second electric motor; at least one second gear having a larger diameter than that of the first gear, engaged with and driven by the first gear; and a second and a third power generators engaged with the at least one second gear.

In an embodiment of the present invention, the apparatus further includes a center gear engaged with and driven by the at least one second gear, wherein each of the first and second power generators is engaged with and driven by the center gear.

In an embodiment of the present invention, wherein each of the second and third power generators includes a gear shaft engaged with and driven by the center gear to generate electric power.

In an embodiment of the present invention, the apparatus further includes a first base and a second base, wherein the first electric motor, the first power generator and the second electric motor are fixed to the first base, and the second and third power generators are fixed to the second base.

In an embodiment of the present invention, the first electric motor is connected to the first power generator through a jointer.

In an embodiment of the present invention, the apparatus includes a first electric wire for connecting the first power generator and the second electric motor to supply the power generated by the first power generator to the second electric motor.

In an embodiment of the present invention, the second and third power generators are located in parallel with one another and connected through a second electric wire.

In an embodiment of the present invention, one of the second or third power generators is connected to a power transformer to supply the power generated by the second and third power generators to a grid or to the first electric motor.

In an embodiment of the present invention, the second and third generators rotate at the same RPM.

### BRIEF DESCRIPTION OF THE DRAWINGS

These and other aspects will become apparent and more readily appreciated from the following description of the embodiments, taken in conjunction with the accompanying drawings of which:

FIG. 1 is a perspective view of an apparatus of the present invention.

The features and advantages of the present invention will become more apparent from the detailed description set forth below when taken in conjunction with the drawings in which like reference numbers indicate identical or functionally similar elements.

## DETAILED DESCRIPTION

Reference will now be made in detail to embodiments, examples of which are illustrated in the accompanying drawings, wherein like reference numerals refer to the like elements throughout. In this regard, the present embodiments may have different forms and should not be construed as being limited to the descriptions set forth herein. Accordingly, the embodiments are merely described below, by referring to the figures, to explain aspects of the present description. Terms used herein are for descriptive purposes only and are not intended to limit the scope of the invention. The terms “comprises” and/or “comprising” are used to specify the presence of stated elements, steps, operations, and/or components, but do not preclude the presence or addition of one or more other elements, steps, operations, and/or components. The terms “first”, “second, and the like may be used to describe various elements, but do not limit the elements. Such terms are only used to classify one element from another.

These and/or other aspects will become apparent and more readily appreciated from the following description of embodiments of the present invention, taken in conjunction with the accompanying drawing.

An aspect of the present invention provides an apparatus (20) that includes a first electric motor (2); a first power generator (5) connected to and driven by the first electric motor (2) to generate power; a second electric motor (7) driven by the power generated by the first power generator (5); a first gear (9) engaged with and driven by the second electric motor (7); at least one second gear (10) having a larger diameter than that of the first gear (9), engaged with and driven by the first gear (9); a second and a third power generators (13, 14) engaged with the at least one second gear (10). The first electric motor (2) is driven by electric power, being connected to AC or DC power through a connector wire (1), and may have a rotating shaft (3) that drives the first power generator (5). The rotating shaft (5) may be connected to a jointer connected to the shaft of the first power generator (5) driven by the first electric motor (2). The first power generator (5) generates power supplied to the second electric motor (7) which in turn rotates the first gear (9). The first gear (9) may be an integral part of the shaft of the second electric motor (7) or a separate part engaged with the second electric motor (7). The first gear (9) may be engaged with the at least one second gear (10) which has a larger diameter than that of the first gear (9). In a preferred embodiment, there may be two second gears (10), one having a larger diameter than that of the other and which are intermediate gears connecting the second electric motor (7) with the second and third power generators (13, 14).

In another preferred embodiment of the present invention, the first or second electric motors (2, 7) may be provided with a pulley, and the first, second and third power generators (5, 13, 14) may be provided with another pulley, so that the power generators (5, 13, 14) may be driven by the electric motors (2, 7) through a belt connecting with the pulleys.

In another embodiment of the present invention, the second electric motor (7) may be provided with a chain gear engaging with directly the second and third power generators (13, 14) having another chain gear through a chain belt.

In a preferred embodiment of the present invention, the apparatus (20) further includes a center gear (11) engaged with and driven by the at least one second gear (10), wherein each of the second and third power generators (13, 14) has a gear shaft (8, 12) engaged with and driven by the center gear (11) to generate electric power. The center gear (11) may have the same diameter as the gear shaft (8, 12) of the second and

3

third power generators (13, 14) and engages with both the second and third power generators (13, 14), being located therebetween as shown in FIG. 1, such that the RPM of the second and third power generators is at the same rate. In a different embodiment of the present invention, the second power generator (7) may be engaged with the second and third power generators (13, 14) through the center gear (11).

In an embodiment of the present invention, the apparatus (20) further includes a first base and a second base, wherein the first electric motor (2), the first power generator (5) and the second electric motor (7) are fixed to the first base, and the second and third power generators (23, 14) are fixed to the second base.

In an embodiment of the present invention, the first electric motor (2) is connected to the first power generator (5) through a jointer (4).

In an embodiment of the present invention, the apparatus (20) includes a first electric wire (6) for connecting the first power generator (5) and the second electric motor (7) to supply the power generated by the first power generator (5) to the second electric motor (7).

In an embodiment of the present invention, the second and third power generators (13, 14) are located in parallel with one another and connected through a second electric wire (15).

In an embodiment of the present invention, one of the second or third power generators (13, 14) is connected to a power transformer (16) to supply the power generated by the second and third power generators (13, 14) to a grid (17) or to the first electric motor (2).

In a preferred embodiment of the present invention, the second and third generators (13, 14) rotate at the same RPM, for example at 1,800 RPM, having capacity of generating 400 kW.

It should be understood that the exemplary embodiments described therein should be considered in a descriptive sense only and not for purposes of limitation. Descriptions of features or aspects within each embodiment should typically be considered as available for other similar features or aspects in other embodiments.

What is claimed is:

1. An apparatus comprising:

at least one electric motor provided with one of a gear or a pulley; and

at least one power generator provided with one of another gear or another pulley engaging with the gear or the pulley, wherein the at least one electric motor drives the

4

at least one power generator and the at least one electric motor rotates at the same speed with the at least one power generator,

wherein the at least one electric motor comprises a first electric motor, and the at least one power generator comprises a first power generator connected to and driven by the first electric motor to generate power, the apparatus further comprising:

a second electric motor driven by the power generated by the first power generator;

a first gear engaged with and driven by the second electric motor;

at least one second gear having a larger diameter than that of the first gear, engaged with and driven by the first gear;

a second and a third power generators engaged with the at least one second gear.

2. The apparatus of claim 1, wherein each of the gears of the at least one electric motor and the at least one power generator is a chain gear, being connected with one another through a chain.

3. The apparatus of claim 1, wherein the pulleys of the at least one electric motor and the at least one power generator are connected with one another through a belt.

4. The apparatus of claim 1, further comprising a center gear engaged with and driven by the at least one second gear, wherein each of the first and second power generators is engaged with and driven by the center gear.

5. The apparatus of claim 4, wherein each of the first and second power generators includes a gear shaft engaged with and driven by the center gear to generate electric power.

6. The apparatus of claim 1, wherein the first electric motor is connected to the first power generator through a jointer.

7. The apparatus of claim 1, further comprising a first electric wire for connecting the first power generator and the second electric motor to supply the power generated by the first power generator to the second electric motor.

8. The apparatus of claim 1, wherein the second and third power generators are located in parallel with one another and connected through a second electric wire.

9. The apparatus of claim 8, wherein one of the second or third power generator is connected to a power transformer to supply the power generated by the second and third power generators to a grid or to the first electric motor.

10. The apparatus of claim 1, wherein the second and third generators rotate at the same RPM.

\* \* \* \* \*